

ZINTRA CLOUDS

DOME - CONCAVE

INSTALLATION INSTRUCTIONS

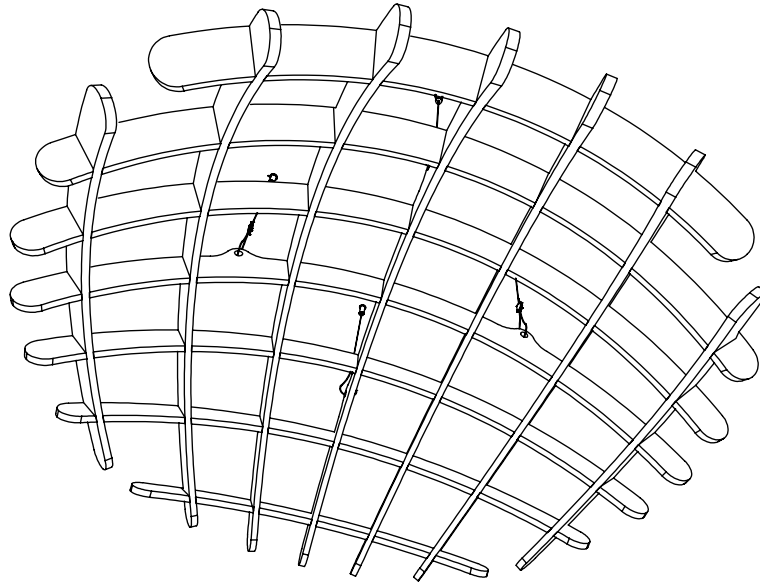

BOTTOM PERSPECTIVE

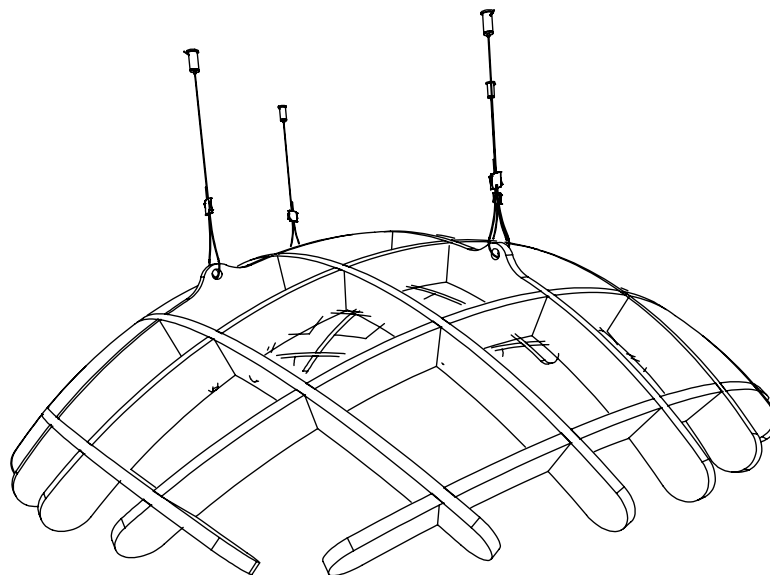

TOP PERSPECTIVE

ZINTRA CLOUDS

DOME - CONCAVE

INSTALLATION INSTRUCTIONS

PARTS AND HARDWARE

ZINTRA CLOUDS - CONCAVE

PARTS WILL COME FLAT PACKED WITH A TOTAL OF 14 PARTS

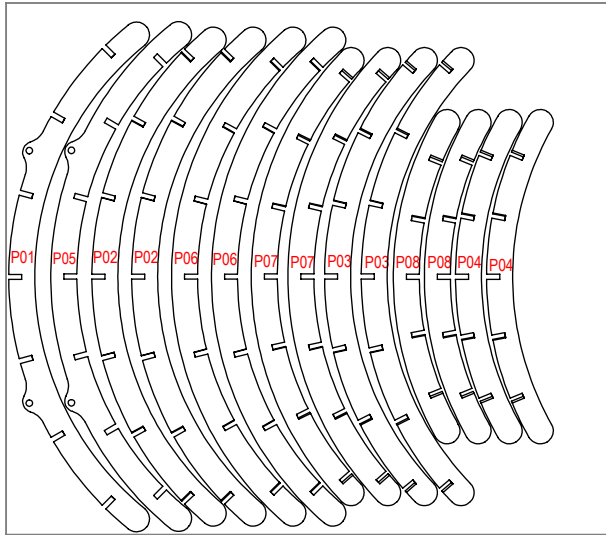

TOTAL PIECES: 14

P01: 1
P02: 2
P03: 2
P04: 2
P05: 1
P06: 2
P07: 2
P08: 2

(4) 1/4" - 20 HANGER BOLT (FOR USE WITH WOOD SUBSTRATE ONLY)



(4) ADJUSTABLE FASTENER



(4) CABLE WITH SWAGE END, AND BARREL

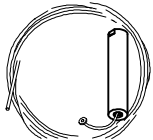

ZINTRA CLOUDS

DOME - CONCAVE

INSTALLATION INSTRUCTIONS

YOU WILL NEED

SPIRIT LEVEL

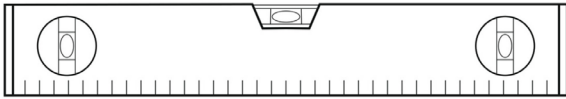

DROP SAW WITH SUITABLE BLADE FOR ALUMINIUM CUTTING

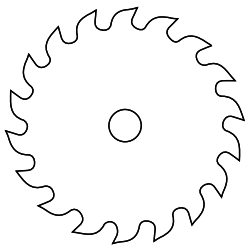

DRILL

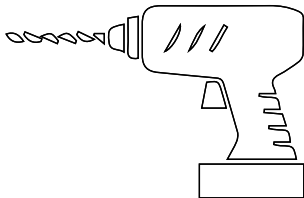

TAPE MEASURE

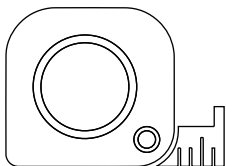

ZINTRA CLOUDS

DOME - CONCAVE

INSTALLATION INSTRUCTIONS

STEP 1

CHECK TO SEE IF PACKAGE CONTAINS ALL COMPONENTS. EVERY PART WILL COME WITH A NUMBER (FROM 1-8) TO REPRESENT THE CLOUD NUMBER.

THERE WILL BE A TOTAL OF 14 CLOUD PARTS:

- P01: 1
- P02: 2
- P03: 2
- P04: 2
- P05: 1
- P06: 2
- P07: 2
- P08: 2

AND (4) OF EACH: HANGER BOLT, ADJUSTABLE FASTENER, CABLE WITH SWAGE END AND BARREL.

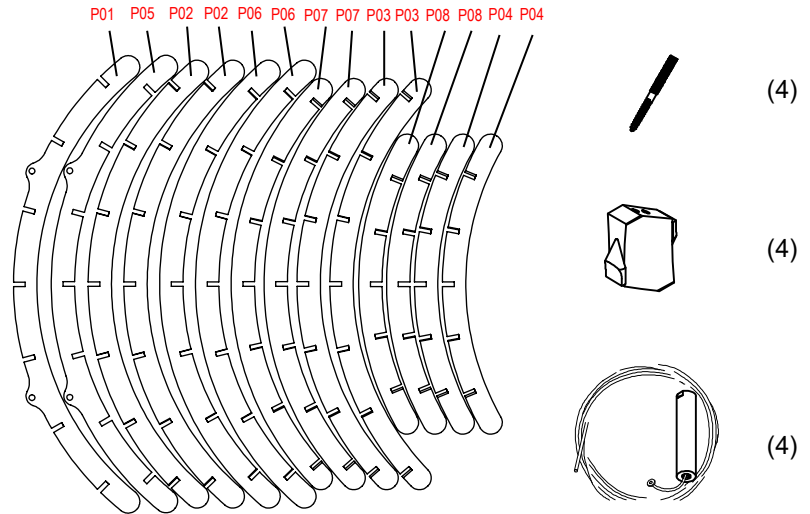

STEP 2

CONNECT P01 (NOTCHES FACING UPWARDS) TO P05 (NOTCHES FACING DOWNWARDS) VIA THE CENTRE NOTCH.

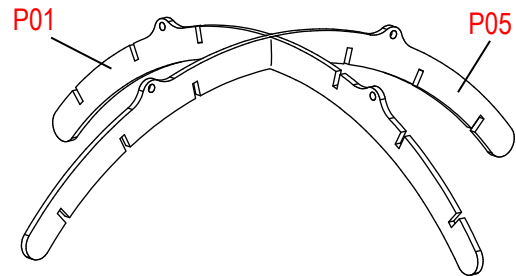

STEP 3

ADD CLOUDS WITH NOTCHES FACING UPWARDS. WORKING FROM THE INNER CLOUDS TO OUTER AS SHOWN FROM STEPS A TO C.

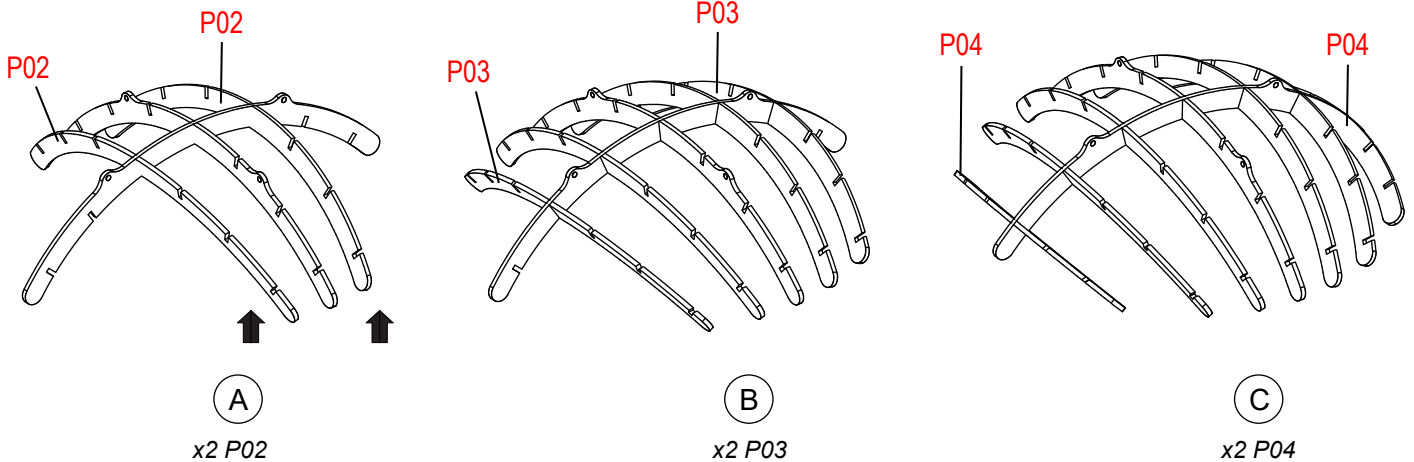

ZINTRA CLOUDS

DOMES - CONCAVE

INSTALLATION INSTRUCTIONS

STEP 4

IMPORTANT NOTE: MAKE SURE THE NOTCHES ARE FACING TOWARDS THE CENTRE. THIS IS TO ALLOW FOR THE REMAINING CLOUDS TO FOLLOW THE "DOME" PROFILE.

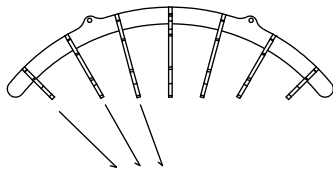

FRONT VIEW
CLOUDS FACING INWARDS

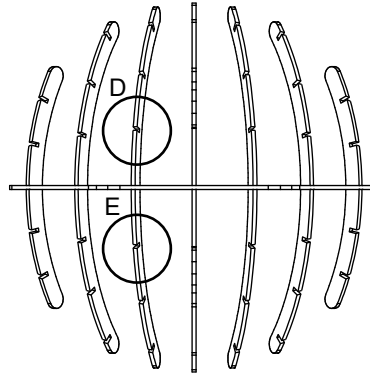

TOP VIEW

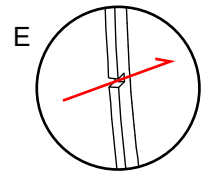
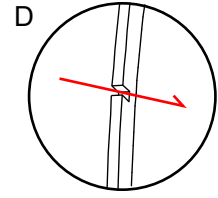

STEP 5

ADD CLOUDS WITH NOTCHES FACING DOWNWARDS. WORKING FROM THE INNER CLOUDS TO OUTER AS SHOWN FROM STEPS A TO C.

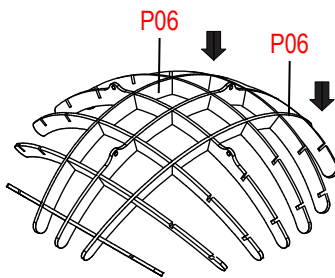

(A)

x2 P06

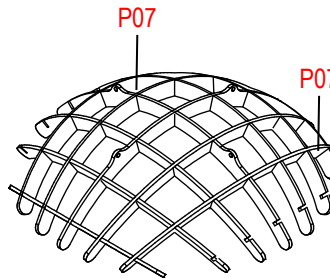

(B)

x2 P07

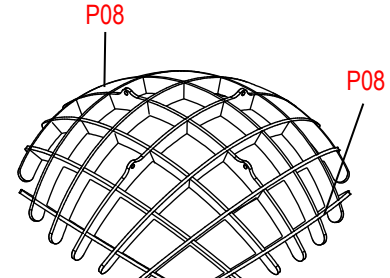

(C)

x2 P08

STEP 6

IMPORTANT NOTE: (SAME AS STEP 4) MAKE SURE THE NOTCHES ARE FACING TOWARDS THE CENTRE. THIS IS TO ALLOW FOR THE REMAINING CLOUDS TO FOLLOW THE "DOME" PROFILE.

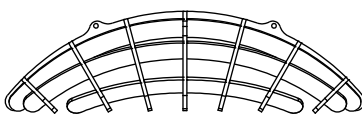

FRONT VIEW
CLOUDS FACING INWARDS

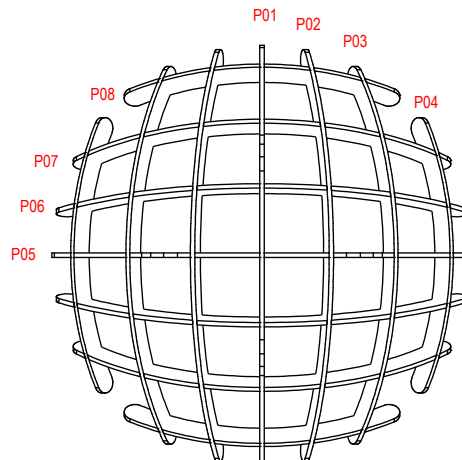

TOP VIEW

ZINTRA CLOUDS

DOMES - CONCAVE

INSTALLATION INSTRUCTIONS

STEP 7

A. FIND THE MIDPOINT OF EACH A.S.K (LOCATED ON P01). DIMENSION ARE GIVEN [A]

A. FIND THE MIDPOINT OF EACH A.S.K (LOCATED ON P05). DIMENSION ARE GIVEN [B]

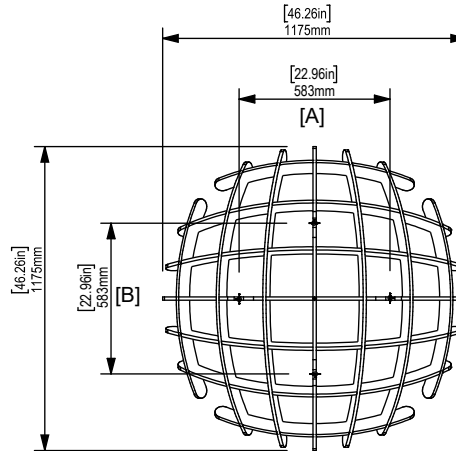

STEP 8

AFTER IDENTIFYING EACH CORRESPONDING POINT ON THE CEILING SUBSTRATE, TO THE POINTS MARKED ON STEP 7, DRILL AND ATTACH 1/4"-20 DOUBLE SIDED HANGER BOLT TO SUBSTRATE. REFERENCE DETAIL (SUPPLIED FOR WOOD ANCHORING ONLY). FOR ALL OTHER SUBSTRATES, STUDS/ ANCHORS MUST BE SOURCED BY THE INSTALLER.

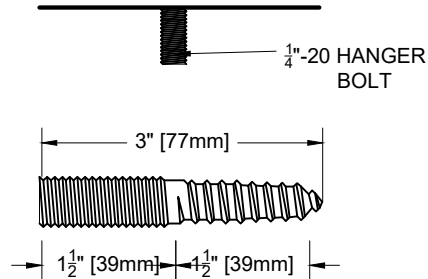

STEP 9

A. IDENTIFY THE THREADED END OF THE BARREL AND THE SWAGE END OF THE WIRE.

B. INSERT THE PLAIN END OF THE SUPPLIED WIRE THROUGH THE LARGE THREADED END OF THE BARREL UNTIL THE SWAGE END IS SEATED IN THE BARREL.

C. ATTACH THE THREADED END OF THE BARREL TO 1 / 4"-20 HANGER BOLT.

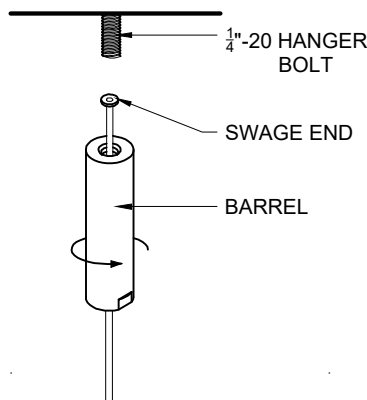

ZINTRA CLOUDS

DOME - CONCAVE

INSTALLATION INSTRUCTIONS

STEP 10

A. INSERT THE PLAIN END OF THE SUPPLIED WIRE THROUGH ONE SIDE OF THE ADJUSTABLE FASTENERS.

B. LOOP THE WIRE AROUND THE CROSSRUNNER WHERE MARKED.

C. RE-INSERT THE PLAIN END OF THE WIRE INTO THE REMAINING SIDE OF THE ADJUSTABLE FASTENER UNTIL SECURE.

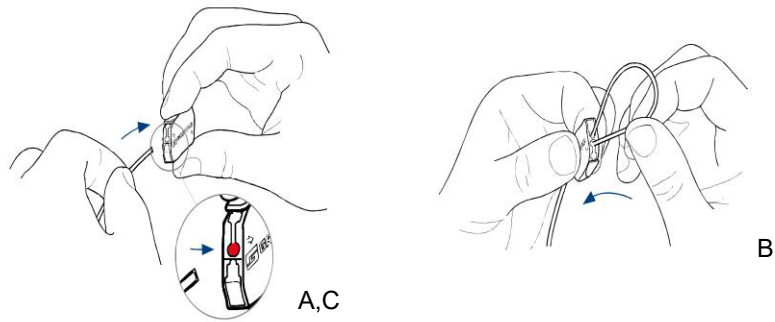

STEP 11

ONCE THE HANGING KIT IS PROPERLY SUSPENDED, TRIM THE EXCESS WIRE (IF NECESSARY) WITH WIRE CUTTERS.

NOTE: WIRE IS INFINITELY ADJUSTABLE BY DEPRESSING TAB ON APPROPRIATE SIDE.

